



GENERAL KNOWLEDGE

General Instruction for Pneumatic Actuator

For your own safety, please read the instruction below before you inquiring / using our products.

Precautions in piping / installment

- According to the required driving torque and select corresponding actuator specifications by the output torque standard data in the 4Bar air pressure when install the valve. Actuator's torque should be more than 25% of the valve's torque requirement.

- The correct installation is directly affect the integral performance. The central axis of actuator MUST BE coaxial with the valve pole. Please notice the valve and the actuator needs to turn off the connection, examine the valve, after fix by using the right screw, opening and closing should not be any phenomenon about suddenly fast, suddenly slow, or stop.

- When piping with the large pneumatic valve, because of the weight of the valve, please install the support frame to avoid deformation of pipeline and valve body.

- Please confirm there's enough space for maintenance or manual operation.

- Actuator contains fine adjustment screw to ensure the opening and closing positions correct.

- To keep its best situation, please arrange regular inspect and change parts by its usage frequency. The air source should be kept dry and clean, and also drainage and sewage regularly for air filter components at the front end.

- Actuator's switch can be controlled by Single-acting or Double-acting 5 ports 2 ways solenoid valve.

- Please double check the pipeline direction, any leak wire connection before using the valve.

Malfunction detection and elimination

Situation	Check item	Solution
Valve unable to move	Check the solenoid valve, coil, and the core are malfunction or not.	Exchange solenoid, coil, clean impurities.
	Examine the pneumatic acuator, check sealing parts and cylinder.	Exchange sealing parts and cylinder.
	Impurities stuck the piston inside the actuator.	Clean impurities, and replace broken parts.
	If there's extra manual mechanism, its handle in the manual position.	Switch the handle to pneumatic control.
Valve works slow, inching	Insufficient pneumatic pressure.	Increase pressure.
	Spool and other parts assembly uneven or too tight.	Increase actuator model spec.
	Actuator output torque too small.	Reassemble parts.
	Pneumatic pipeline block or flow too small.	Remove clog, replace filter.
Limit switch no signal feedback	Power circuit error or break.	Overhaul circuit.
	Cam incorrect position in the switch.	Adjust Cam to the correct position.
	Micro switch damaged.	Replace limit switch

Main parts & Material

No.	Part name	Material
1	Gear output shaft	Carbon steel
2	Valve body	Extrude aluminum alloy
3	Cover	Die-cast aluminum alloy
4	Spring component	Alloy steel
5	Fine adjustment screw	Stainless steel
6	Position indicator	PP
7	Piston	Die-cast aluminum alloy
8	Wear ring	NYLON 46
9	Cover screw	Stainless steel
10	O-ring	NBR

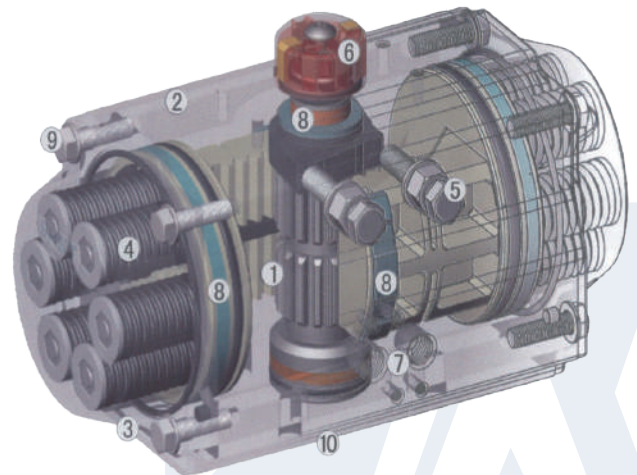



GENERAL KNOWLEDGE

Principle of operation for Double acting torque.

Valve OFF

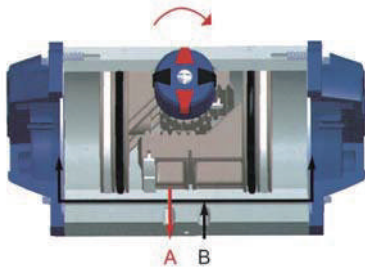

Compressed air input by **B Port**, make the piston and output shaft turn clockwise. Close the valve. Expel the air in the piston by **A port**.

Valve ON

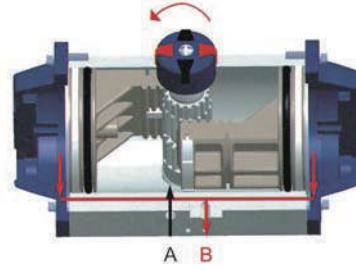

Compressed air input by **A Port**, make the piston and output shaft turn counterclockwise. Open the valve. Expel the air in the piston by **B port**.

Double acting torque reference

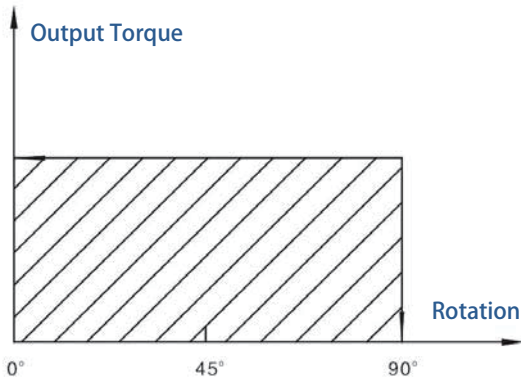

Model	Input pneumatic pressure (Torque unit : Nm)							
	3.5 Bar	4 Bar	4.5 Bar	5 Bar	5.5 Bar	6 Bar	7 Bar	8 Bar
AT32D	5	5.7	6.5	7.3	8	8.7	10	11.6
AT50D	11.7	13.5	15.1	16.7	18.4	20	23.4	26.7
AT63D	20.6	23.6	26.5	29.4	32.3	35.3	41.1	47
AT75D	40.8	46.6	52.5	58.3	64.1	69.9	81.5	93.2
AT88D	64.2	73.3	82.5	91.6	101.1	110.1	128.1	146.1
AT100D	93.4	106.3	120.3	133.3	146.3	160.3	186.3	213.3
AT115D	150	172	193	215	236	258	301	344
AT125D	195	223	250	278	303	333	389	444

AT Series Overall Dimension (mm)

Model	A	B	C	E	F	P
AT32D	118	45	1/8"	77	47	40

Model	A	B	C	E	F	P
AT50D	144	70.5	1/8"	99	69	40
AT63D	163	83.5	1/8"	115	85	40
AT75D	214	94	1/8"	132	102	40
AT88D	252	105	1/8"	145	115	40
AT100D	270	120	1/4"	157	127	40
AT115D	316	138	1/4"	185	145	62
AT125D	354	147	1/4"	197	157	62

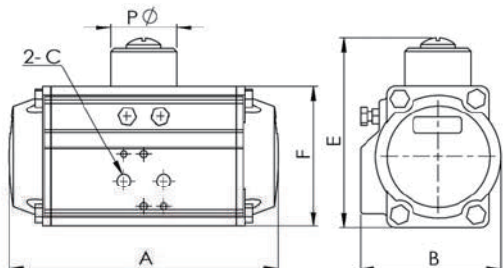
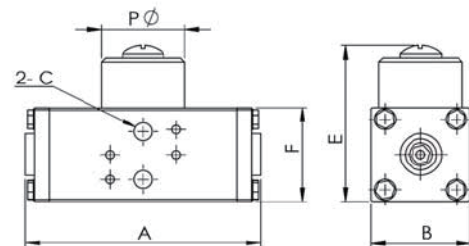
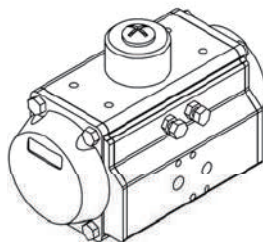
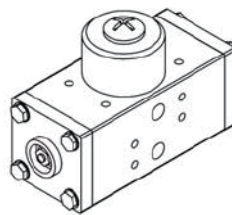



PRODUCT/ PNEUMATIC VALVE

PLF Series Pneumatic Flange Angle Valve



Specifications Characteristics

Model	PLF Series
Structure	External pneumatic guidance, piston type.
Fluid	Air, Inert gas, Water, Light oil, Organic solvents
Medium Temp.	-5°C - 120°C
Environment	Temp. -10 - 55°C ; Humidity. 10 - 90% RH
Caliber	DIN16 Flange DN15 - DN80
Pressure	0 - 1.2 Mpa
Material	Stainless steel 304 ; 316
Valve rod Mat.	Stainless steel 304
Gasket Mat.	PTFE
Actuator Mat.	Nylon
Signal press.	0.4 - 0.8 Mpa
Installation	According to the flow direction.

How to select model

PLF32 - 63 A S1

Valve body spec.

Spec	Diameter	Code
1/2	DN15	PLF15
3/4	DN20	PLF20
1	DN25	PLF25
1-1/4	DN32	PLF32
1-1/2	DN40	PLF40
2	DN50	PLF50
2-1/2	DN65	PLF65
3	DN80	PLF80
4	DN100	PLF100

Actuator spec.

Spec	Diameter	Actuator
1/2	DN15	50
3/4	DN20	50
1	DN25	63
1-1/4	DN32	63
1-1/2	DN40	63
2	DN50	80
2-1/2	DN65	80
3	DN80	100
4	DN100	125

Acting method

Acting method	Code
Single acting N.C.	A
Single acting N.O.	B
Double acting	D

Valve body material

Material	Code
SUS304	S1
SUS316	





PRODUCT/ PNEUMATIC VALVE

Actuator parameters (Mpa)

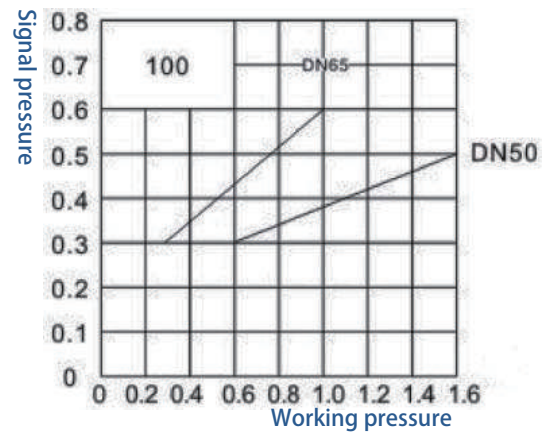
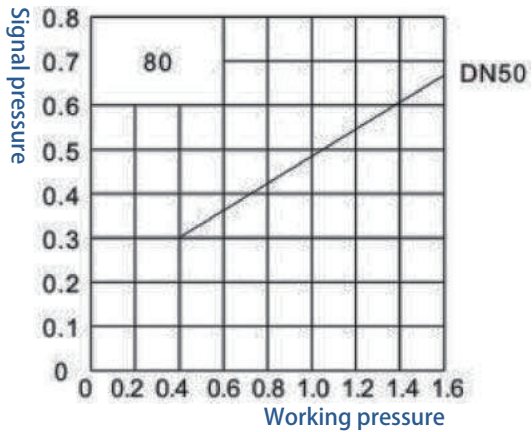
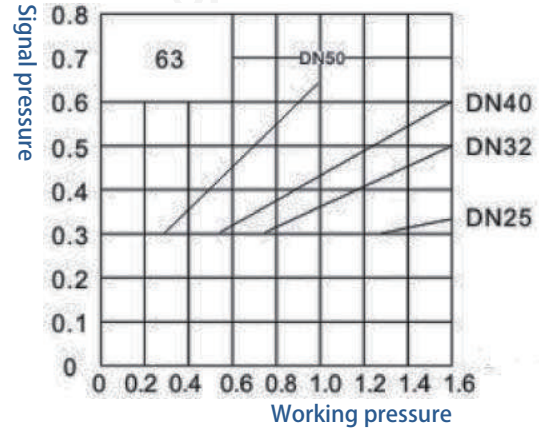
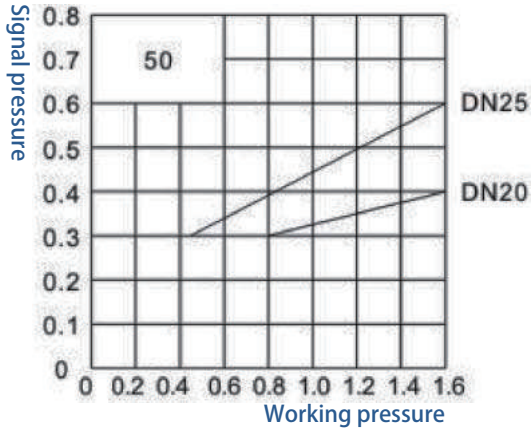

Pressure unit : Mpa

Specification	Diameter	KV (m ³ /h)	Actuator Spec.	Minimum pressure	Maximum pressure	Minimum signal pressure	Maximum signal pressure
3/8	DN10	50	50	0	1.2	0.4	0.8
1/2	DN15	50	50	0	1.2	0.4	0.8
3/4	DN20	50	50	0	1.2	0.4	0.8
1	DN25	63	63	0	1.2	0.4	0.8
1-1/4	DN32	63	63	0	1.2	0.4	0.8
1-1/2	DN40	63	63	0	1.2	0.4	0.8
2	DN50	80	80	0	1.0	0.4	0.8
2-1/2	DN65	80	80	0	1.0	0.4	0.8
3	DN80	100	100	0	0.8	0.4	0.8
4	DN100	125	125	0	0.8	0.4	0.8



PRODUCT/ PNEUMATIC VALVE

Flow direction

流向：閥座上方 單作用常閉/常開
Flow direction:UP the seat, single acting normal close /open

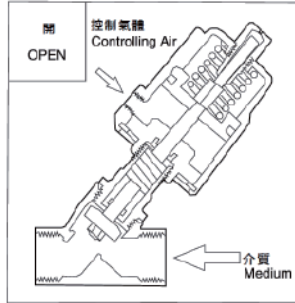
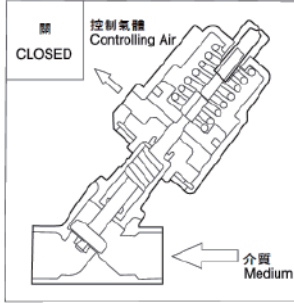

流向：閥座上方 雙作用常閉/常開
Flow direction:UP the seat, double action N.C/N.O

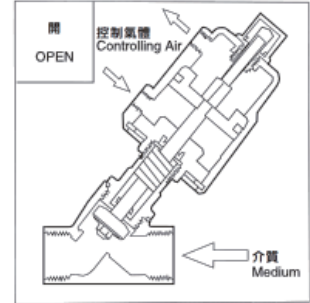
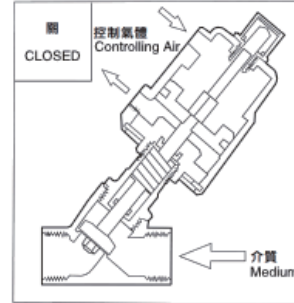

Dimensions

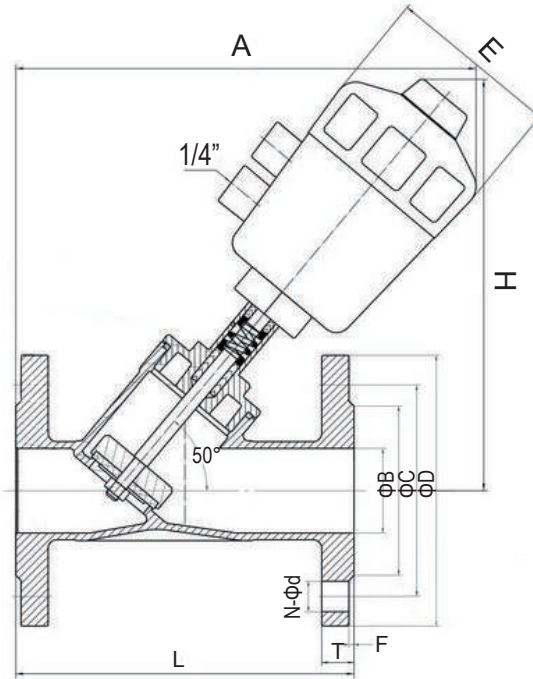

Unit : MM

Model	Actuator	L	T	F	D	C	B	N-Ød	A	H	E
PLF15	50	120	14	2	95	65	40	4-14	180	64	65
PLF20	50	130	14	2	105	75	50	4-14	185	64	85
PLF25	63	140	14	2	115	85	60	4-14	220	80	95
PLF32	63	150	16	2	135	100	70	4-18	240	80	105
PLF40	63	180	16	2	145	110	80	4-18	245	80	120
PLF50	80	195	16	2	160	125	92	4-18	265	100	130
PLF65	80	230	18	2	185	145	115	4-18	280	100	150
PLF80	100	250	18	2	195	160	135	8-18	320	126	185
PLF100	125	280	18	2	215	180	150	8-18	360	156	220